

LCD MASTER 11

TOPARC

- **Filtre actif : teintes 3 / 11**
- **Protection UV/ IR DIN 15**
- **Pas de pile**



Ref. 043442

► TABLEAU TECHNIQUE

Classification	1/1/1/1
Teinte claire	3
Teinte foncée	11
Temps de réaction	0,0005 sec
Temps de retour au clair	auto
Champs de vision	100x49 mm
Energie	solaire
Poids	430 g
Capteur lumineux	2
Champs d'applications	MMA 10►150 / TIG 10►175 / MIG-MAG 10►200
Normes	EN 175 / EN 379

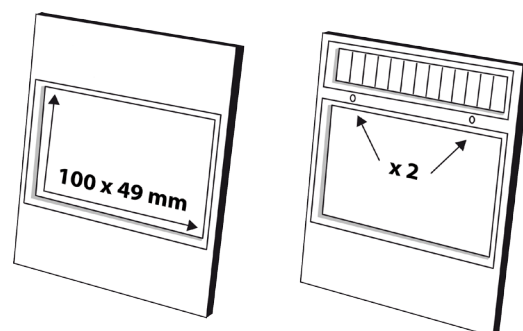

solaire

► ACCESSOIRES

